

SB600

Liquid Cooled Bi-Fuel Diesel Engine Generator Sets

Standby Power Rating

600KW 60 Hz / 620KVA 50 Hz

Prime Power Rating

547KW 60 Hz / 590KVA 50 Hz

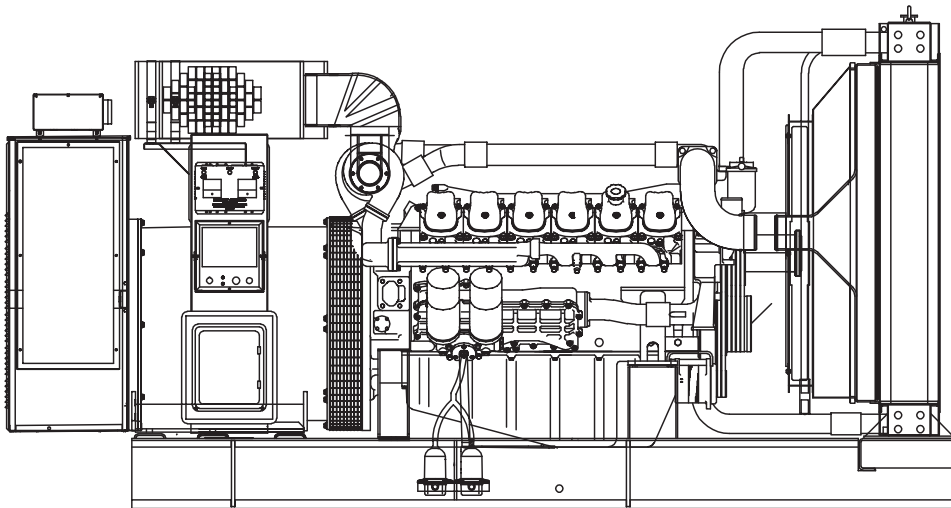

Power Matched

GENERAC 22.0DTA ENGINE

Turbocharged / Aftercooled

Tier II Compliant

FEATURES

- **INNOVATIVE DESIGN & PROTOTYPE TESTING** are key components of GENERAC'S success in "IMPROVING POWER BY DESIGN." But it doesn't stop there. Total commitment to component testing, reliability testing, environmental testing, destruction and life testing, plus testing to applicable CSA, NEMA, EGSA, and other standards, allows you to choose GENERAC POWER SYSTEMS with the confidence that these systems will provide superior performance.
- **TEST CRITERIA:**
 - ✓ PROTOTYPE TESTED
 - ✓ SYSTEM TORSIONAL TESTED
 - ✓ ELECTRO-MAGNETIC INTERFERENCE
 - ✓ NEMA MG1 EVALUATION
 - ✓ MOTOR STARTING ABILITY
 - ✓ SHORT CIRCUIT TESTING
 - ✓ UL 2200 COMPLIANCE AVAILABLE
- **POWERMANAGER® DIGITAL CONTROL PLATFORM.** The PowerManager® Digital Control Platform (PM-DCP) is a powerful control system built around a 32-bit, industrial microprocessor. Standard factory programming controls the entire engine/generator system, while allowing the PM-DCP, with its onboard PLC, to be customized to meet any application requirement. The system is available on single unit gas, diesel or bi-fuel installations as well as Modular Paralleling Systems (MPS) from 350 kW - 3000 kW.
- **BI-FUEL** provides low cost, low volume fuel storage and operation along with a 40% reduction in fuel costs.
- **SINGLE SOURCE SERVICE RESPONSE** from Generac's dealer network provides parts and service know-how for the entire unit, from the engine to the smallest electronic component. You are never on your own when you own a GENERAC POWER SYSTEM.
- **ECONOMICAL DIESEL POWER.** Low cost operation due to modern diesel engine technology. Better fuel utilization plus lower cost per gallon provide real savings.
- **LONGER ENGINE LIFE.** Generac heavy-duty diesels provide long and reliable operating life.
- **GENERAC TRANSFER SWITCHES, SWITCHGEAR AND ACCESSORIES.** Long life and reliability is synonymous with GENERAC POWER SYSTEMS. One reason for this confidence is that the GENERAC product line includes its own transfer systems, accessories, switchgear and controls for total system compatibility.

GENERAC®

GENERATOR SPECIFICATIONS

TYPE Marathon Four-pole, revolving field PMG
 ROTOR INSULATION Class H
 STATOR INSULATION Class H
 ADDITIONAL INSULATION Antifungal Coating
 TOTAL HARMONIC DISTORTION <5%
 TELEPHONE INTERFERENCE FACTOR (TIF) <50
 BEARINGS Prelubed and Sealed
 COUPLING Direct Connected
 LOAD CAPACITY(Standby Rating) 100%
 WINDING PITCH 2/3

VOLTAGE REGULATOR

Regulation Digitally Controlled \pm 0.25%
 Sensing Single or 3 Phase
 Paralleling Capability Yes

CONTROL PANEL

Type PowerManager Digital Control Platform

DISPLAY

AC Volts Line to Line and Line to Neutral
 AC Amps Per line
 Frequency 10-99 Hertz
 Oil Pressure Digital Touchscreen LCD
 Coolant Temperature Digital Touchscreen LCD
 Fuel Level Digital Touchscreen LCD
 DC Battery Voltage Digital Touchscreen LCD
 Hour Meter - Run Time Hours Digital Touchscreen LCD
 Engine Speed in RPM Digital Touchscreen LCD
 Generator Power kW Digital Touchscreen LCD
 Power Factor Digital Touchscreen LCD
 Turbo Pressure Digital Touchscreen LCD
 Gas Pressure Digital Touchscreen LCD
 Gas Flow (CFM) Digital Touchscreen LCD
 Air Temperature (Incoming) Digital Touchscreen LCD
 Gas Temperature Digital Touchscreen LCD
 Charge Air Cooler Valve Position Digital Touchscreen LCD
 Not in Auto Digital Touchscreen LCD
 Common Alarm Digital Touchscreen LCD

ALARMS

High/Low Generator Voltage Digital Touchscreen LCD
 High/Low Battery Voltage Digital Touchscreen LCD
 High/Low Frequency Digital Touchscreen LCD
 Low Oil Pressure & Prealarm Digital Touchscreen LCD
 High, Low, Critical Low Fuel Level Digital Touchscreen LCD
 Overcrank Digital Touchscreen LCD
 Sensor Failure Digital Touchscreen LCD

COMMUNICATION

Serial Communication RS232 and RS485
 GenLink Software for PowerManager® Digital Control Platform

ENGINE SPECIFICATIONS

MAKE Generac / Doosan
 MODEL P222FE/6DWXL21.9UYA
 CYLINDERS V12
 DISPLACEMENT 22 Liter (1338 cu. in.)
 BORE 128 mm (5.04 in.)
 STROKE 142 mm (5.60 in.)
 COMPRESSION RATIO 15:1
 INTAKE AIR Turbocharged, Aftercooled
 CYLINDER HEAD (6) 1-Cylinder Cast Iron with Overhead Valve
 PISTONS Heat Resistant Aluminum Alloy

ENGINE SPECIFICATIONS Cont.

VALVE TRAIN

LIFTER TYPE Solid
 HARDENED VALVE SEATS Replaceable

ENGINE GOVERNOR

ELECTRONIC Standard
 FREQUENCY REGULATION, NO-LOAD TO FULL LOAD 0.5%
 STEADY STATE REGULATION \pm 0.25%

LUBRICATION SYSTEM

TYPE OF OIL PUMP Gear
 OIL FILTER Bypass and Full flow, cartridge
 CRANKCASE CAPACITY 42 Liters (11.1 U.S. gal.)

ENGINE FEATURES

ECONOMICAL POWER Microprocessor controlled bi-fuel diesel engine starts on diesel fuel and provides power from an air/natural gas mixture ignited by diesel injection and continuously monitored by the on board control.

LONGER ENGINE LIFE Generac heavy duty bi-fuel diesels provide long and reliable operating life along with low emissions.

EMISSIONS Capable of low particulate and NOx emission levels.

HOW DOES A BI-FUEL ENGINE WORK?

The diesel engine is equipped with a metering system that feeds natural gas into the incoming air supply. The standard diesel injection system is used and the injector sprays diesel fuel into the cylinder at the correct time. The diesel fuel ignites and thus ignites the natural gas charge. Total power is derived from a combination of natural gas and diesel as shown in the chart below. The ratio of natural gas to diesel fuel is a function of several factors, including load and intake air temperature. The higher thermal efficiency of diesel engines and the lower cost of natural gas, along with low emission levels, combine to make the bi-fuel engine a very economical choice.

FUEL PRESSURE - NAT. GAS 1 psi FUEL CONSUMPTION

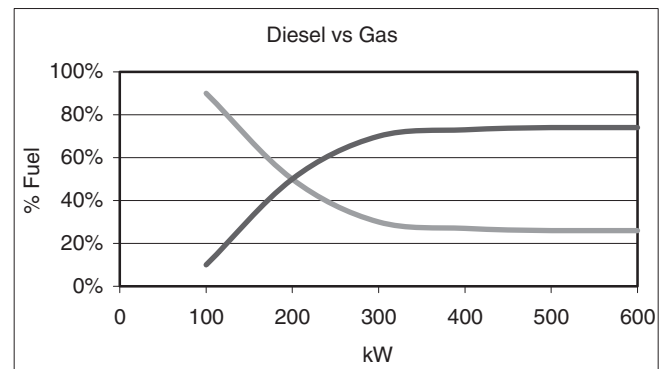

Load kW	Gal/Hr Diesel w/Nat Gas	Gal/Hr Straight Diesel	% Nat Gas	Cu.Ft./hr. Nat Gas
100	8	8.9	10%	125
200	8.5	17.0	50%	1187
300	7.5	24.8	70%	2431
400	8.5	31.4	73%	3206
500	9.7	37.2	74%	3843
600	11	43.3	74%	4480

SB600

OPERATING DATA

	STANDBY		PRIME	
	SB600		SB600	
GENERATOR OUTPUT VOLTAGE/KW—60Hz	Rated kW	Rated AMP	Rated kW	Rated AMP
120/208V, 3-phase, 0.8 pf	600	2082	547	1898
120/240V, 3-phase, 0.8 pf	600	1806	547	1645
277/480V, 3-phase, 0.8 pf	600	902	547	822
600V, 3-phase, 0.8 pf	600	722	547	658
NOTE: Consult your Generac dealer for additional voltages.				
MOTOR STARTING KVA	Low Wye & Delta	High Wye	Low Wye & Delta	High Wye
Maximum @ 35% instantaneous voltage dip with standard alternator; 60 Hz-kVa	1760	1765	1760	1765
FUEL				
Fuel pump lift in.	39		39	
Natural Gas (920 BTU minimum) pressure	1 psi		1 psi	
COOLING				
Coolant capacity System - lit./gal.	131 (34.6)		131 (34.6)	
Engine - lit./gal.	36 (9.5)		36 (9.5)	
Radiator - lit./gal.	95 (25)		95 (25)	
Coolant flow/min. 60 Hz - lit./gal.	870 (230)		870 (230)	
Heat rejection to coolant @ FL BTU/hr.	1,740,000		1,390,000	
Inlet air 60 Hz - m ³ /min. (cfm)	665 (23,500)		665 (23,500)	
Max. air temp onto radiator* °C (°F)	60 (140)		60 (140)	
Max. ambient temperature* °C (°F)	50 (122)		50 (122)	
Max. external pressure drop on radiator in. H ₂ O	0.5		0.5	
COMBUSTION AIR REQUIREMENTS				
Flow at rated power 60 Hz - m ³ /min. (cfm)	55.5 (1959)		48.6 (1716)	
EXHAUST				
Exhaust flow at rated output 60 Hz - m ³ /min. (cfm)	182 (6419)		159 (5615)	
Maximum recommended back pressure Kpa (" Hg)	5.1 (1.5)		5.1 (1.5)	
Exhaust temp. at rated output °C (°F)	704 (1300)		616 (1141)	
Exhaust outlet size inches (mm.)	2 x 8 (203.2) or 1 x 10 (254)		2 x 8 (203.2) or 1 x 10 (254)	
ENGINE				
Rated RPM 60 Hz	1800		1800	
HP at rated KW 60 Hz	954		935	
Piston speed 60 Hz - m/sec. (ft./min)	8.5 (1677)		8.5 (1677)	
BMEP 60 Hz - PSI	313		274	
POWER ADJUSTMENTS FOR AMBIENT CONDITIONS**				
Temperature				
4.1% for every 10°C above - °C	40		40	
2.4% for every 10°F above - °F	104		104	
Altitude				
0.8% for every 100 m above - m.	1067		1066	
2.6% for every 1000 ft. above - ft.	3500		3500	

* Note: Values given are maximum temperatures to which power adjustments can be applied. Consult your Generac Power Systems representative if operating conditions exceed these maximums.

** Note: Consult Factory for high altitude cooling options.

- High Coolant Temperature Automatic Shutdown
- Low Coolant Level Automatic Shutdown
- Low Oil Pressure Automatic Shutdown
- Overspeed Automatic Shutdown (Solid-state)
- Crank Limiter (Solid-state)
- Oil Drain Extension
- Radiator Drain
- Factory-Installed Cool Flow Radiator
- Closed Coolant System
- UV/Ozone Resistant Hoses
- Rubber-Booted Engine Electrical Connections
- Stainless Steel Flexible Exhaust Connection
- Battery Charge Alternator
- Battery Cables
- Battery Tray
- 24 Volt, Solenoid-activated Starter Motor
- Air Cleaner
- Fan Guard
- Control Console
- Isochronous Governor
- Jacket water heater
- Vibration Isolators

POWERMANAGER® DIGITAL CONTROL PLATFORM

The PowerManager® Generator Controller (PM-GC) is a fully programmable, integrated digital generator control console using a 32-bit industrial microprocessor to handle all control, monitoring, input/output genset functions. The open architecture used allows customizing the controls to meet any customer requirement, yet maintaining the simplicity of operation 'as is' with the factory default programming. (see Generac bulletin #0168840SBY)

OPTIONS

■ OPTIONAL COOLING SYSTEM ACCESSORIES

- Radiator Duct Adapter

■ OPTIONAL FUEL ACCESSORIES

- Base Tank Low Fuel Alarm
- Primary Fuel Filters
- UL Listed Fuel Tanks
- Electric fuel transfer pump system

■ OPTIONAL ELECTRICAL ACCESSORIES

- 10A Dual Rate Battery Charger
- Battery, 24 Volt
- Battery warmer

■ OPTIONAL ALTERNATOR ACCESSORIES

- Alternator Upsizing
- Alternator Heater
- Main Line Circuit Breaker
(factory installed up to 2000 Amp.)

■ OPTIONAL EXHAUST ACCESSORIES

- Critical Exhaust Silencer
- Residential Exhaust Silencer
- Industrial Exhaust Silencer

■ ADDITIONAL OPTIONAL EQUIPMENT

- Automatic Transfer Switch
- 21 Light Remote Annunciator
- Remote Relay Panels
- Oil Make-Up System
- Oil Heater
- 5 Year Warranties
- Export Boxing
- GenLink® Communications Software

■ OPTIONAL ENCLOSURES

- Weather Protective
- Sound Attenuated
- Aluminum

Distributed by:

